

SGH OPERATOR (DESIGNED FOR CONTINUOUS USE)

SUPER-DUTY GEAR-HEAD OPERATORS

Standard Features and Benefits

- ▶ Compact operator/mounting configuration is ideal for coiling doors - operators always fit within the coil height dimension
- ▶ Consistent mounting, appearance and wiring - across full line of operator models
- ▶ Considerably lighter weight than competitive gear-head operator models
- ▶ Auxiliary chain for emergency operation, just pull to operate
- ▶ UL Listed
- ▶ Programmable seven segment LED display
- ▶ Cycle counter
- ▶ Terminal connection for a monitored entrapment protection device
- ▶ Programmable timer to close
- ▶ Mid-open timer dry contact open warning timer
- ▶ Open warning timer (dry contact only)
- ▶ Onboard open and close limit signaling connections
- ▶ 24 VDC warning output signal when the door is moving
- ▶ On board Open/Close/Stop buttons
- ▶ Close override if the entrapment protection device short circuits

Option

- ▶ Module for secondary monitored entrapment protection device

Standard Components

Drive Reduction: Lubricated, heavy-duty gears.

Auto-Reset Thermal Protection: Prevents motor burnout.

Limit Switches: Linear driven, fully adjustable screw-type cams.

Operator Safety Feature: Activating "Open," "Stop" or a remote transmitter button stops the movement of a closing door.

Pre-Wired for Sensing Edge/Sensing Devices: A sensing edge, photo eyes or other detection devices can be easily connected. Standard one second time delay prior to reversing prevents damage to door and operator.

Standard Exterior Radio-Control Terminal: Provides for easy and fast connection of radio controls.

Brake: Maintenance free, solenoid actuated brake. No adjustment required for the life of the operator.

Bearings: Heavy-duty bearings are used at all rotation points.

Auxiliary Chain Hoist: Automatically engages and disengages as hand chain is operated. Cut off switch prevents motor operation when the chain is in use.



MOTOR OPERATOR **SGH OPERATOR SUPER-DUTY GEAR-HEAD OPERATORS**

Models

Model	SGH 50	SGH 75	SGH 100	SGH 150	SGH 200
Horsepower	1/2 hp	3/4 hp	1 hp	1 1/2 hp	2 hp
Voltage	115V/230V 460V 575V	115V/230V 460V 575V	115V/230V 460V 575V	115V/230V 460V 575V	230V/460V 575V
Phase	1 & 3	1 & 3	1 & 3	1 & 3	3
Frequency	50 Hz* / 60 Hz	50 Hz* / 60 Hz	50 Hz* / 60 Hz	50 Hz* / 60 Hz	50 Hz* / 60 Hz
Duty	Continuous	Continuous	Continuous	Continuous	Continuous
Drive Chain	#50	#50	#60	#60	#80
Auxiliary Hand Chain	Included	Included	Included	Included	Included

Note: 3, 5 and 7 1/2 HP operators are available. Contact Cornell for details.
 Above products are protected by patent #6,055,885. Other patents are pending.
 * Additional lead time will apply. Please contact factory for details.

Mounting Options

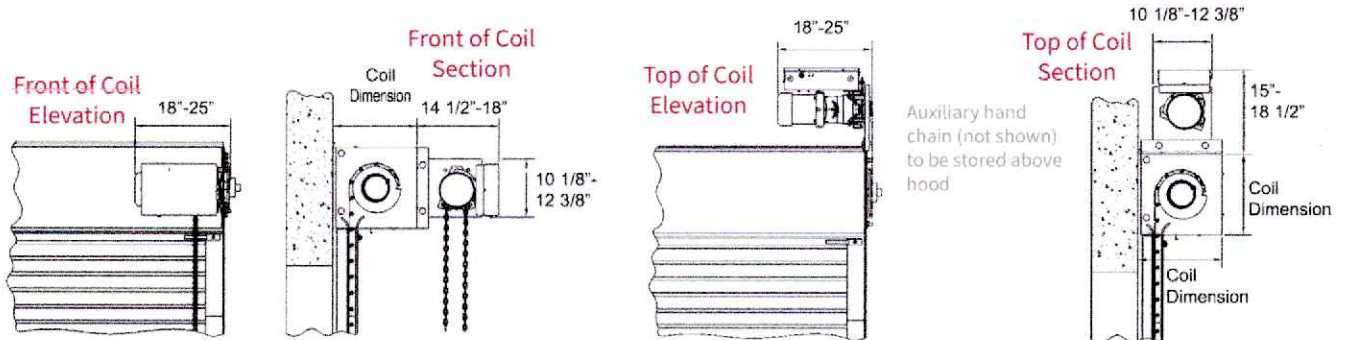

Details and Clearances

